



Indication Panel for mandatory indications of EN 54-16 for VX-2000 and SX-2000

IP-EN1-EB

 1134
TOA Electronics Europe GmbH Süderstrasse 282, 20537 Hamburg, Germany 14 1134 - CPR - 102 1134 - CPR - 110
EN 54-16: 2008 Fire detection and fire alarm systems - Part 16: Voice alarm control and indicating equipment

■ Description

The indication panel IP-EN1-EB is designed to provide the mandatory indications as required by EN 54-16: 2008 for the VX-2000 and SX-2000 system. Additional 8 indicators can be used to indicate faults in fire zones (this is an option with requirements in the EN 54-16) or other faults (EN 54-16 requires yellow indications for faults). A buzzer sounds at every new fault and can be silenced by depressing the acknowledge button. The lamp test button allows checking the proper operation of all indicators and the buzzer. All faults can be reset by using a key.

In addition to above, indication panel IP-EN1-EB provides a general fault output with a switch-over relay that can be equipped with optional resistors for a surveillance of the connected fire detection system (FDS) (the surveillance must be performed by the FDS). It also provides one emergency control input that can either be activated by making/breaking a contact or by a voltage of 12 or 24 VDC (depending on jumper setting). It supports the change between emergency and normal mode / silence, controlled by a single contact of the FDS. The voltage-controlled control input allows a fire detection system to monitor connection.

The indications and controls require a certain setting in the software that will be described in this instruction manual.

■ Precautions

- Make sure that the power supply of the IP-EN1-EB is switched off or disconnected when connecting or disconnecting wires to avoid a damage of the IP-EN1-EB.
- Make sure that the jumper settings and connection to external equipment is made correctly, otherwise it may cause malfunctions of the IP-EN1-EB or external equipment as a fire detection system.
- Make sure of right polarity when connecting the power supply and external equipment.

■ **Contents**

1 Abbreviations	3
2 Software and Firmware Versions supporting the Indication Panel	3
3 Nomenclature	3
3.1 Appearance Front	3
3.2 Appearance Rear	4
4 Preparation and Connections to Fire Detection Systems	5
4.1 Overview	5
4.2 General Fault Control Output CN9	6
4.2.1 Make a contact without surveillance.....	6
4.2.2 Make a contact with surveillance.....	6
4.2.3 Break a contact without surveillance	6
4.2.4 Break a contact with surveillance	6
4.3 Emergency Control Input CN13 and System Settings	7
4.3.1 Control Voltage Selection	7
4.3.2 Total Resistance Setting for Voltage Control	7
4.3.3 Making a Contact: Emergency Activation (VX, SX), breaking a contact: Emergency Reset (VX, SX) / Silencing (SX)	8
4.3.4 Making a Contact: Emergency Activation (VX), breaking a contact: Silencing (VX)	8
4.3.5 Breaking a contact: Emergency Activation (VX, SX), making the contact: Emergency Reset (VX, SX) / Silencing (SX)	9
4.3.6 Breaking a contact: Emergency Activation (VX), making the contact: Silencing (VX).....	9
4.3.7 Voltage: Emergency Activation (VX, SX), no voltage: Emergency Reset (VX, SX) / Silencing (SX)	10
4.3.8 Voltage: Emergency Activation (VX), no voltage: Silencing (VX)	10
4.3.9 No Voltage: Emergency Activation (VX, SX) Voltage: Emergency Reset (VX, SX) / Silencing (SX)	11
4.3.10 No Voltage: Emergency Activation (VX) Voltage: Silencing (VX).....	11
5 Connections and Settings for the VX-2000 System	12
5.1 Connections to VX-2000	12
5.2 Settings in the VX-2000 Setting Software.....	13
5.2.1 Mandatory Indication	13
5.2.1.1 Fault Indications	13
5.2.1.2 Status Indications	14
5.2.2 Control Input Settings for Emergency and Button Controls	15
5.2.3 Indication of Failures in Fire Alarm Areas (option of EN 54-16)	15
6 Connection and Settings for the SX-2000 System	16
6.1 Connections to SX-2000	16
6.2 Connections at SX-2000 Components.....	17
6.3 SX-2000 Settings	18
6.3.1 Mandatory Indication	18
6.3.1.1 Fault Indications	18
6.3.1.2 Status Indications	19
6.3.2 Indication of Failures in Fire Alarm Areas (option of EN 54-16)	19
7 Specifications	20
8 Accessories	20
9 Optional Accessories	20

1 Abbreviations

- FA fire area
- FDS fire detection system

2 Software and Firmware Versions supporting the Indication Panel

VX-2000

Setting software version	3.1.0 and higher
Firmware version of VX-2000 (system manager)	3.10 and higher
Firmware version of VX-2000SF	3.00 and higher

SX-2000

Setting software version	3.10 and higher
Firmware version of SX-2000SM	3.10 and higher
Firmware version of SX-2100AI, SX-2000AO, SX-2100AO	3.10 and higher

3 Nomenclature

3.1 Appearance Front

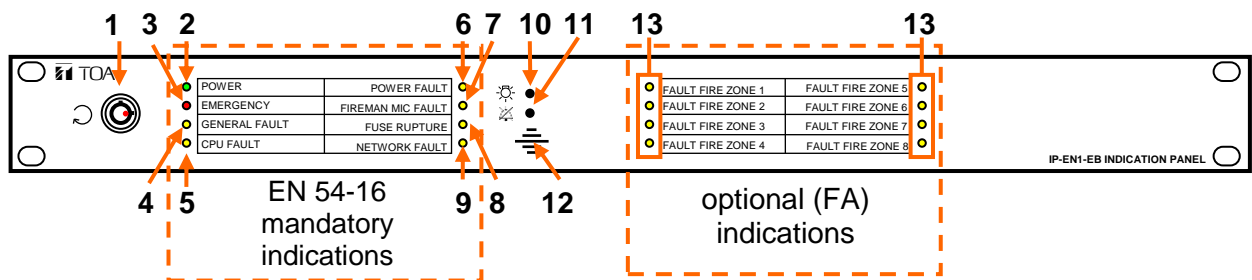

- | | |
|--|--|
| <ul style="list-style-type: none"> 1 Failure reset key lock 2 power indicator 3 emergency mode indicator 4 general fault indicator 5 CPU fault indicator 6 power fault indicator 7 fireman microphone fault indicator | <ul style="list-style-type: none"> 8 fuse rupture indicator 9 network fault indicator 10 lamp test button 11 fault acknowledge button 12 buzzer 13 8 indicators for faults in fire zones or other faults |
|--|--|

3.2 Appearance Rear

Right side (EN 54-16 mandatory indications)

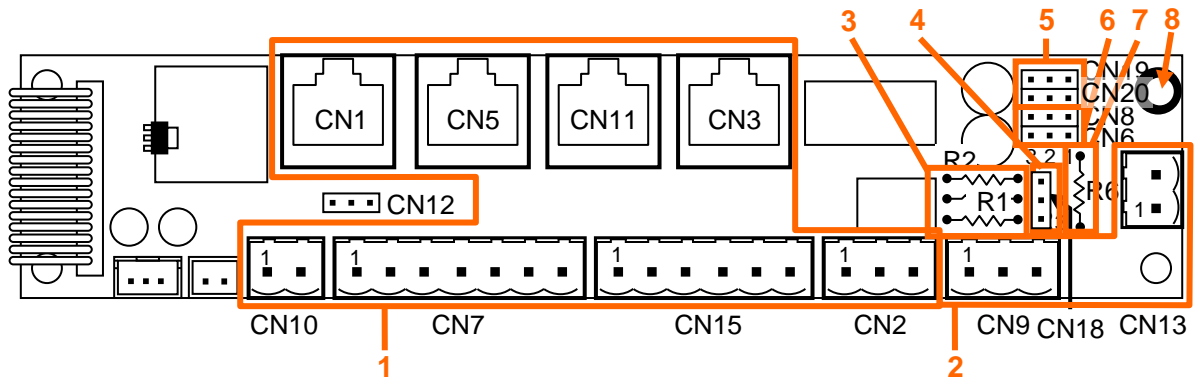

- 1 Connectors to VX-2000/SX-2000
- 2 Connectors to fire detection system (FDS)
- 3 Insertion place for resistors (R1, R2, R3) for surveillance by FDS
- 4 Jumper (CN18) for control voltage selection 12/24 VDC from FDS
- 5 Jumpers (CN19, CN20) for selection pulse/level control from FDS
- 6 Jumpers (CN6, CN8) for selection of contact or voltage control of FDS
- 7 Insertion place for resistor (R6) for resistance matching to FDS (chapter 4.3.2)
- 8 Earth connector: **when using the emergency control input, then connect this point to earth**

Left side (fire area fault indications or other fault indications)

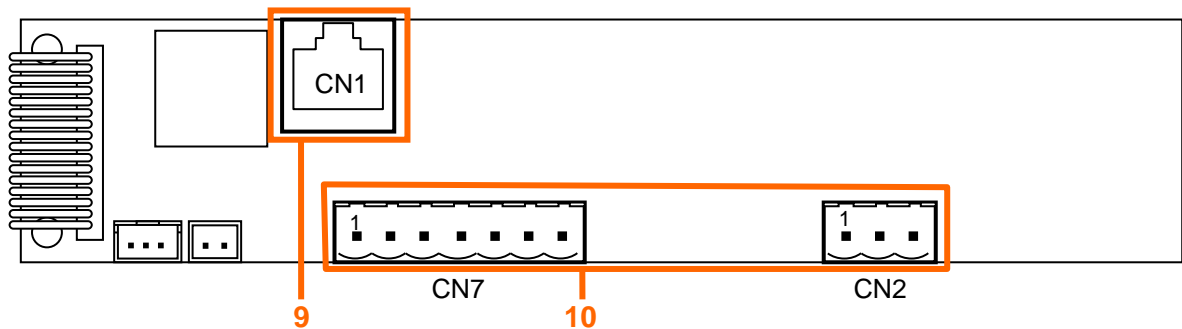

- 9 Connectors to VX-2000 for fault indications in fire areas
- 10 Connectors to SX-2000 for fault indications in fire areas

4 Preparation and Connections to Fire Detection Systems

4.1 Overview

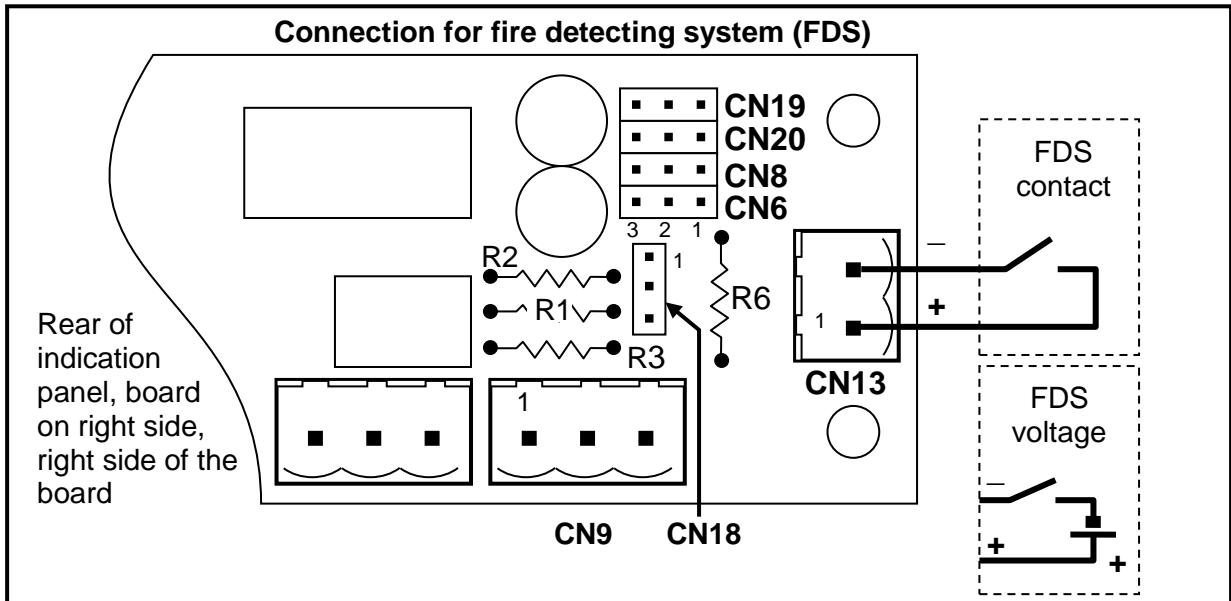

General fault control output CN9

Wire/resistor insertion (R1, R2, R3)

FDS contact output without surveillance

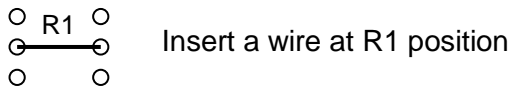

FDS contact output with surveillance

When control output is monitored and activation by making a contact

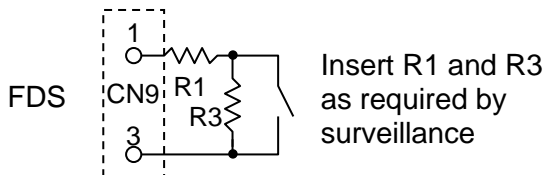

When control output is monitored and activation by breaking a contact

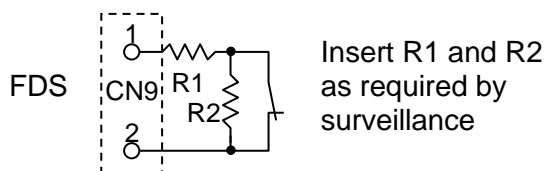

■ jumper

* : factory preset

Refer also to the system settings

Emergency control input CN13

FDS contact/voltage control

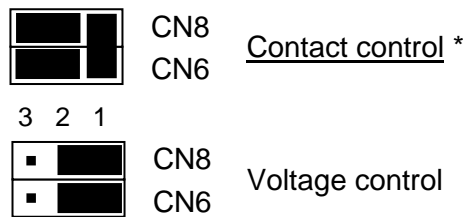

FDS control voltage (CN18 setting)

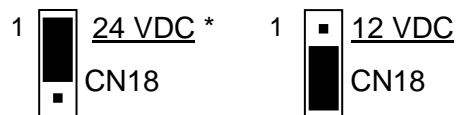

Activation by make contact or voltage on *

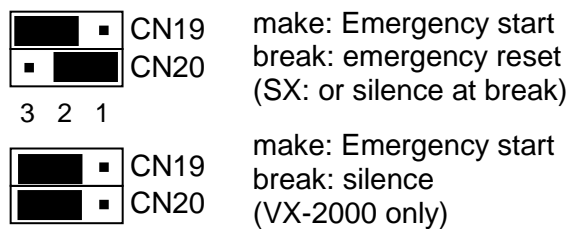

Activation by break contact or voltage off

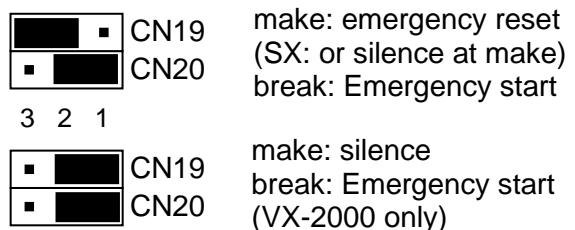

4.2 General Fault Control Output CN9

A general fault information to the fire detection system can be provided in four different ways:

1. make a contact without surveillance
2. make a contact with surveillance
3. break a contact without surveillance
4. break a contact with surveillance

The corresponding settings in the setting software are described in the chapter 5.2 for the VX-2000 system and in the chapter 6.3 of the SX-2000 system.

4.2.1 Make a contact without surveillance

Solder in a wire on position "R1"

Connect to pins 2 and 3 of CN9 to the FDS



4.2.2 Make a contact with surveillance

Solder in resistors R1 and R3 as required by the FDS

Connect to pins 2 and 3 of CN9 to the FDS

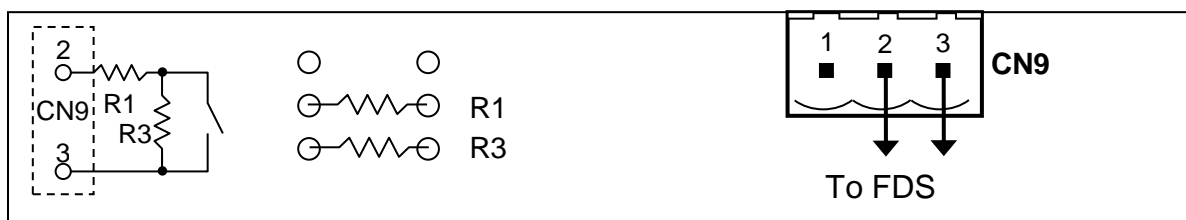

4.2.3 Break a contact without surveillance

Solder in a wire on position "R1"

Connect to pins 1 and 2 of CN9 to the FDS



4.2.4 Break a contact with surveillance

Solder in resistors R1 and R2 as required by the FDS

Connect to pins 1 and 2 of CN9 to the FDS

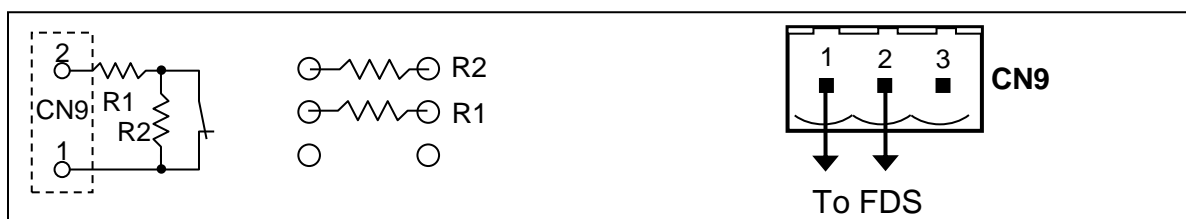

4.3 Emergency Control Input CN13 and System Settings

A single control input with two poles is provided that can be used for activating emergency, and resetting emergency or activating silence. When activating silence, then emergency reset must be controlled by an emergency or fireman microphone, or a separate contact connected directly to the VA system. The corresponding settings in the setting software are described in the chapter 5.2 for the VX-2000 system and in the chapter 6.3 of the SX-2000 system.

There are various combinations to connect the emergency controls from the FDS, please find the settings in the indicated chapter:

VX-2000

Emergency activation				Emergency reset	Silence	chapter
by contact		by voltage				
make	break	on	off			
■				■		4.3.3 *
■					■	4.3.4
	■			■		4.3.5
	■				■	4.3.6
		■		■		4.3.7
		■			■	4.3.8
			■	■		4.3.9
			■		■	4.3.10

* : factory preset

SX-2000

Emergency activation				Emergency reset	Silence	chapter
by contact		by voltage				
make	break	on	off			
■				■	■	4.3.3 *
	■			■	■	4.3.5
		■		■	■	4.3.7
			■	■	■	4.3.9

* : factory preset

4.3.1 Control Voltage Selection

Set the jumper 18 according to the control voltage as shown below:

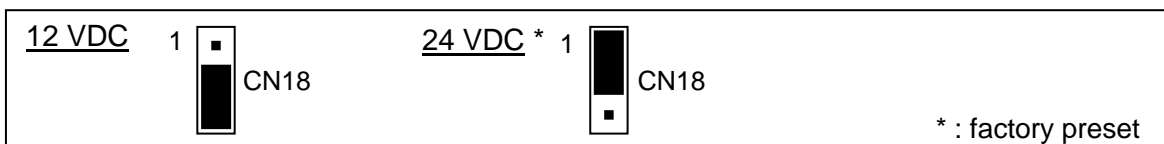

4.3.2 Total Resistance Setting for Voltage Control

If a certain resistance is required at voltage control, then solder in a resistor at position R6.

Resistance FDS	200 Ω	250 Ω	320 Ω	400 Ω	500 Ω	630 Ω	800 Ω	1k Ω
12 VDC [Ω/W]	250 /1	330 /½	470 /½	680 /½	1k /¼	1.8k /¼	3.9k /¼	-
24 VDC [Ω/W]	220 /4	270 /3	390 /2	510 /2	680 /1	910 /1	1.33k /1	2k /½

**4.3.3 Making a Contact: Emergency Activation (VX, SX),
breaking a contact: Emergency Reset (VX, SX) / Silencing (SX)**

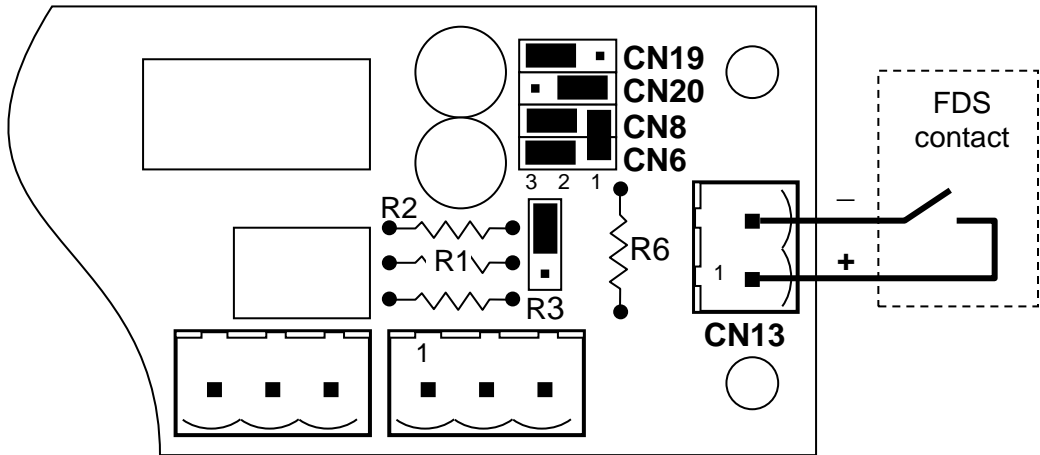

VX-2000 Settings

Connector	Control input	Setting
CN11	1	Emergency pattern start
CN11	2	Emergency reset

SX-2000 Setting

Connector	Control input	Setting
CN15 pin 4	any	Emergency pattern start
CN15 pin 6	any	Emergency reset / silence: emergency pattern stop

**4.3.4 Making a Contact: Emergency Activation (VX),
breaking a contact: Silencing (VX)**

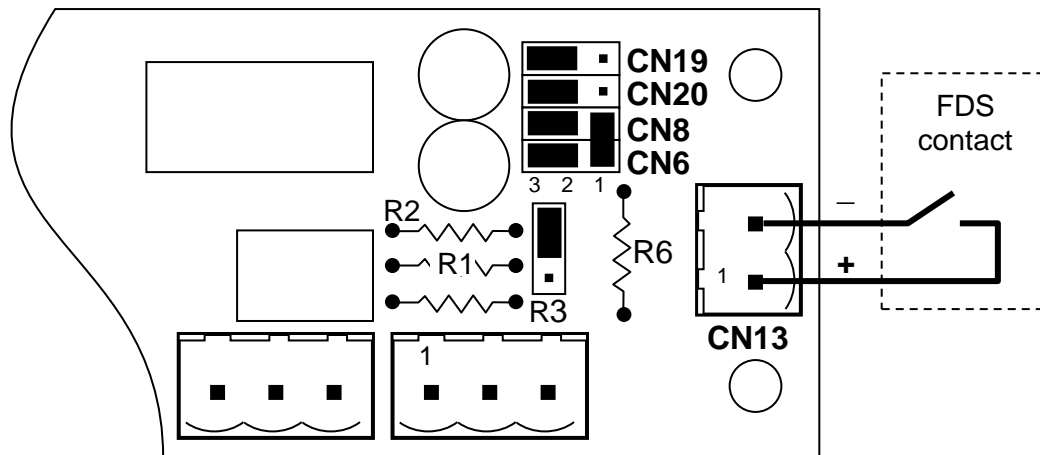

VX-2000 Settings

Connector	Control input	Setting
CN11	1	Emergency pattern start
CN11	2	Silence

**4.3.5 Breaking a contact: Emergency Activation (VX, SX),
making the contact: Emergency Reset (VX, SX) / Silencing (SX)**

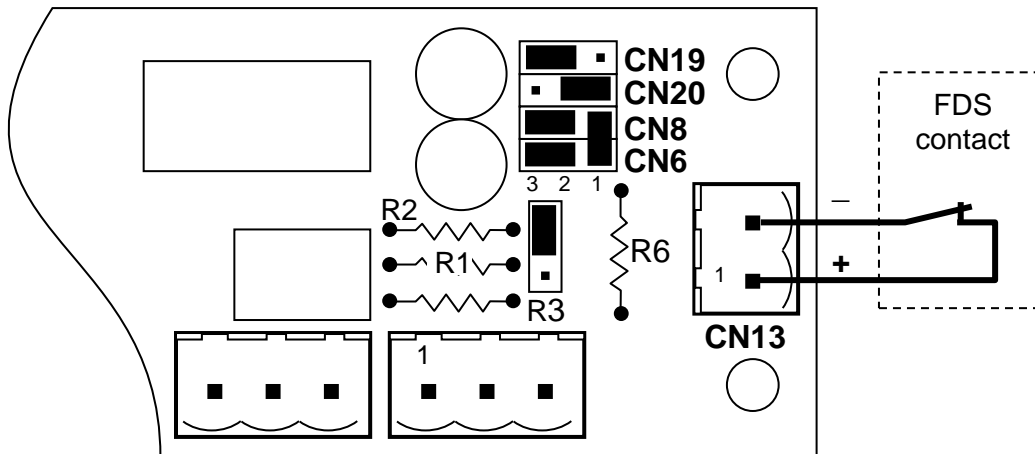

VX-2000 Settings

Connector	Control input	Setting
CN11	1	Emergency reset
CN11	2	Emergency pattern start

SX-2000 Setting

Connector	Control input	Setting
CN15 pin 4	any	Emergency reset / silence: emergency pattern stop
CN15 pin 6	any	Emergency pattern start

**4.3.6 Breaking a contact: Emergency Activation (VX),
making the contact: Silencing (VX)**

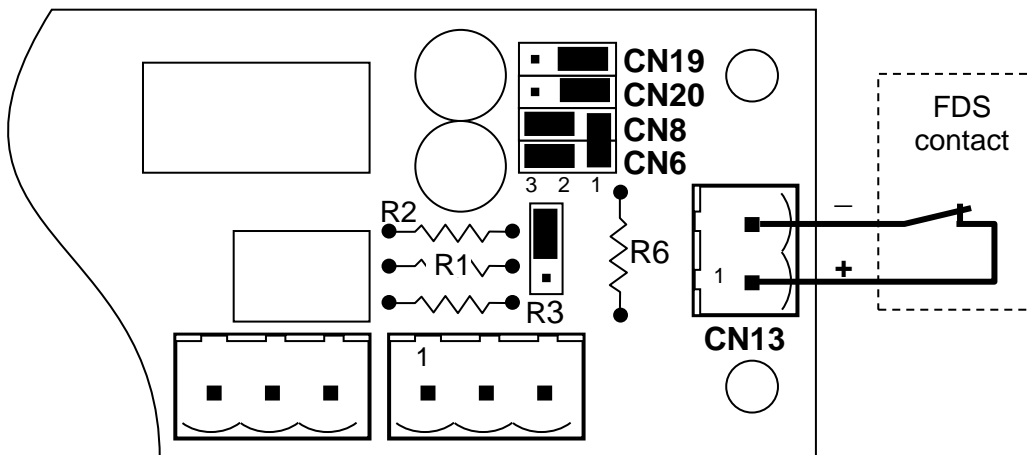

VX-2000 Settings

Connector	Control input	Setting
CN11	1	Silence
CN11	2	Emergency pattern start

**4.3.7 Voltage on: Emergency Activation (VX, SX),
voltage off: Emergency Reset (VX, SX) / Silencing (SX)**

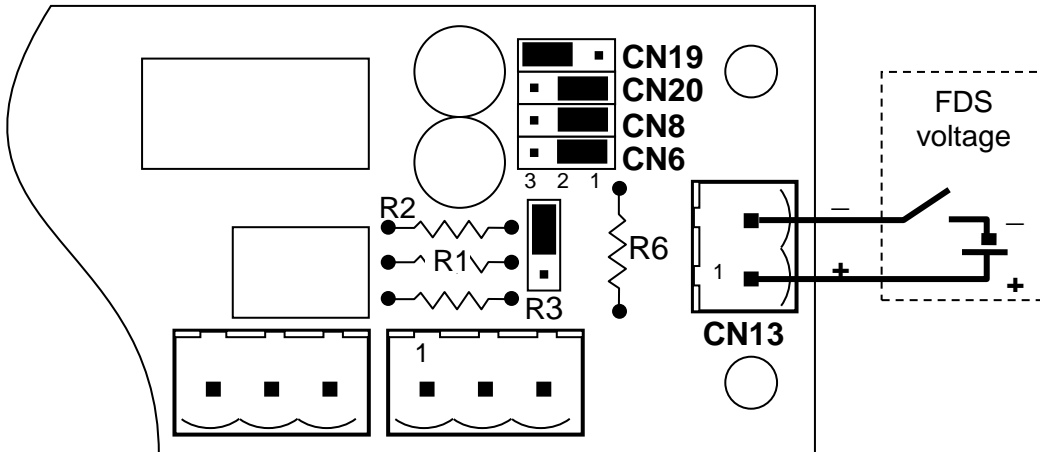

VX-2000 Settings

Connector	Control input	Setting
CN11	1	Emergency pattern start
CN11	2	Emergency reset

SX-2000 Setting

Connector	Control input	Setting
CN15 pin 4	any	Emergency pattern start
CN15 pin 6	any	Emergency reset / silence: emergency pattern stop

**4.3.8 Voltage on: Emergency Activation (VX),
voltage off: Silencing (VX)**

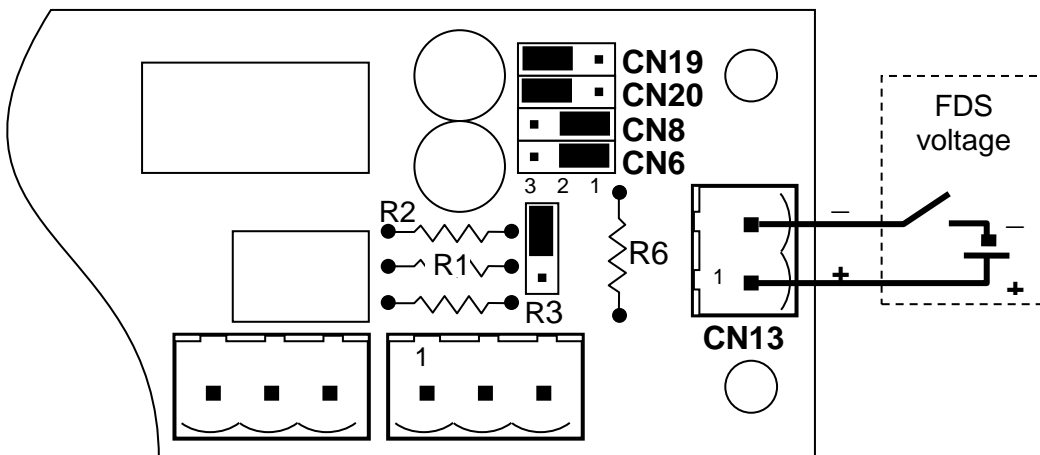

VX-2000 Settings

Connector	Control input	Setting
CN11	1	Emergency pattern start
CN11	2	Silence

**4.3.9 Voltage off: Emergency Activation (VX, SX)
Voltage on: Emergency Reset (VX, SX) / Silencing (SX)**

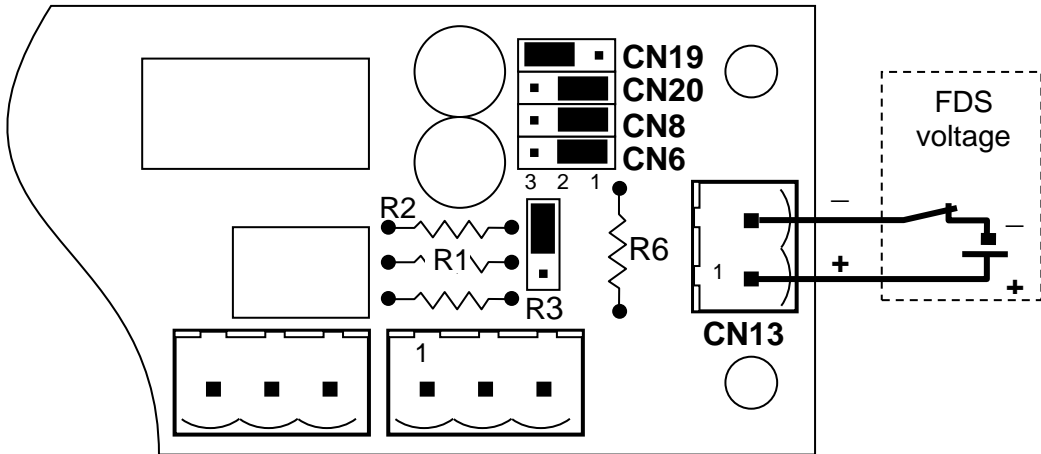

VX-2000 Settings

Connector	Control input	Setting
CN11	1	Emergency reset
CN11	2	Emergency pattern start

SX-2000 Setting

Connector	Control input	Setting
CN15 pin 4	any	Emergency reset / silence: emergency pattern stop
CN15 pin 6	any	Emergency pattern start

**4.3.10 Voltage off: Emergency Activation (VX)
Voltage on: Silencing (VX)**

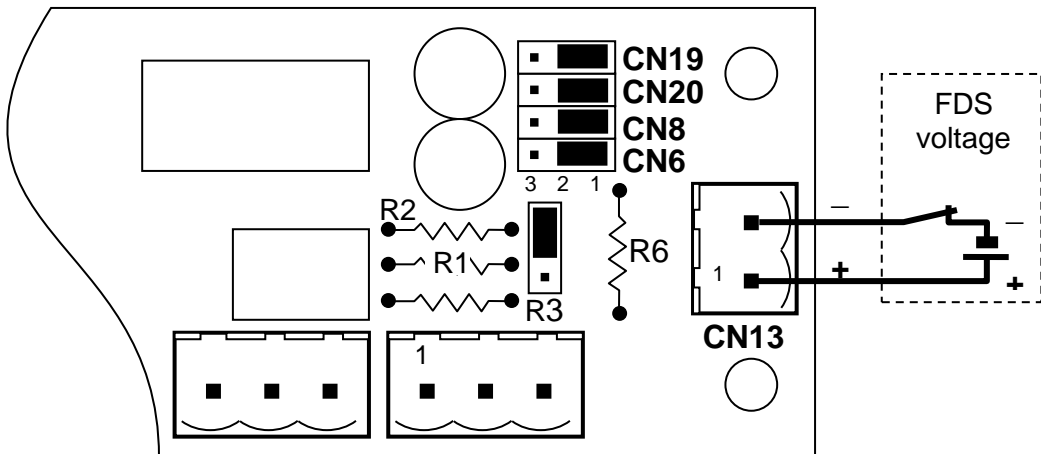

VX-2000 Settings

Connector	Control input	Setting
CN11	1	Silence
CN11	2	Emergency pattern start

5 Connections and Settings for the VX-2000 System

5.1 Connections to VX-2000

Rear right side (mandatory indications)

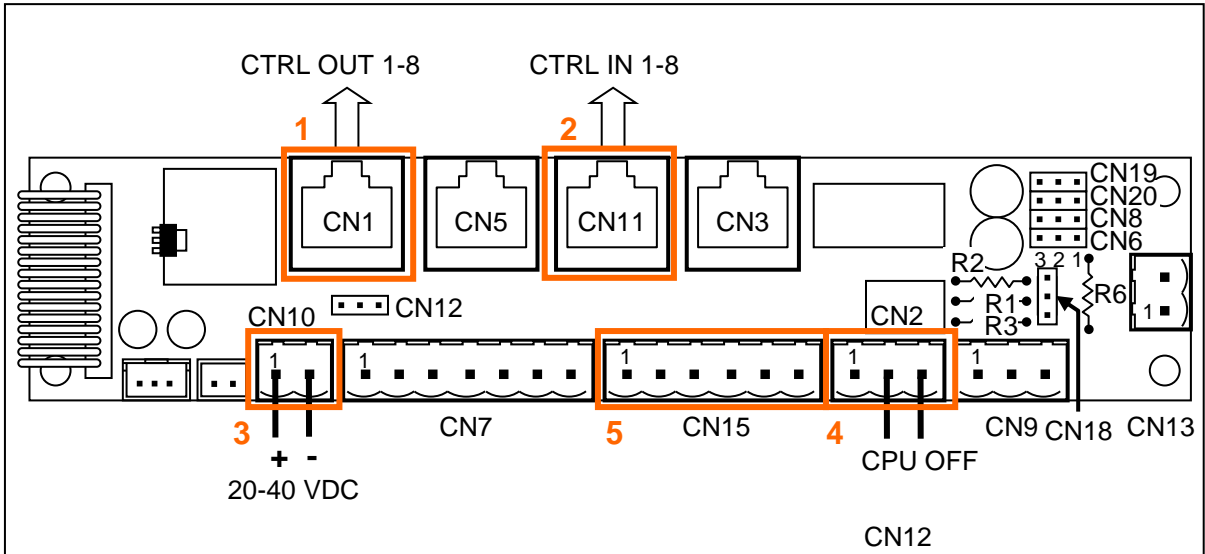

- 1 Connect CN1 to CTRL OUT 1-8 of the VX-2000 (use Cat5/5E/6 FTP or STP or SFTP (with shield))
- 2 Connect CN11 to CTRL IN 1-8 of the VX-2000 (use Cat5/5E/6 FTP or STP or SFTP (with shield))
- 3 Connect CN10 with power supply from VX-2000DS or VX-3000DS (don't connect to regulated 24 VDC), + on pin 1, - on pin 2
- 4 Connect CN2 to the CPU OFF output of the VX-2000, connect to pins 2 and 3
- 5 CN15 provides the access to 4 control inputs of the VX-2000 that are not used by the indication panel and can be used for other control purposes:

CN15 pin no.	1	2	3	4	5	6
VX-2000 control input no.	5	COM	4	7	COM	8

Rear left side (fault indications of fire areas or other fault indications)

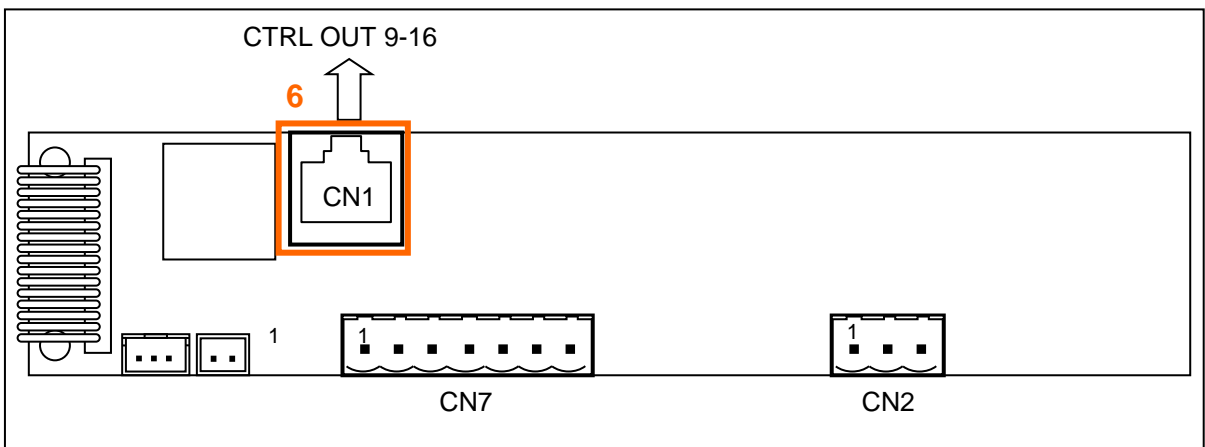

- 6 Connect CN1 (of rear left side) to CTRL OUT 9-16 of the VX-2000 (use Cat5/5E/6 FTP or STP or SFTP (with shield))

5.2 Settings in the VX-2000 Setting Software

5.2.1 Mandatory Indication

5.2.1.1 Fault Indications

No.*	Indication of	VX-2000 connections/ assignment	Settings in Operation setting mode, button [Failure Output]: use one Fault Output Pattern per indication (one line in the list), make a check in
4	General fault	Control output 3	Tab "Equipment" if not noted otherwise: 1. all emergency and fireman microphones 2. external fault C _{IN} connected to the optional Ethernet Switch ** 3. all EV-200M 4. VX-2000 5. all VX-2000SF 6. all amplifiers including the standby amplifier (tab "Power amplifier") 7. all faults (short circuit, open circuit, ground fault) for each loudspeaker line (tab "Speaker") 8. each VX-2000DS connection to VX-2000SF (tab "Power supply")
5	CPU fault	CPU OFF control output	Only connection, no setting
6	Power fault	Control output 5	Tab "Power Supply": each existing VX-2000DS connection to VX-2000SF
7	Fireman/ emergency microphone fault	Control output 6	Tab "Equipment": all emergency and fireman microphones
8	Fuse fault	Control output 4	Tab "Power Amplifier": all amplifiers including the standby amplifier
9	Network fault	Control output 7	Tab "Equipment": external fault C _{IN} connected to the Ethernet Switch if used **
12	buzzer	Control output 8	Enable Failure Buzzer (Cout-8) ***

*: number as on "Appearance Front Panel", page 3

** : refer to next page "Details to number 9"

***: refer to "New function Enable Failure Buzzer"

[]: button of the main menu of the VX-2000 setting software

Details to number 9 (network fault):

When using an NX-100S with IES-3000 series Ethernet switch, then the ports used for the link between decentralised parts of the system on the Ethernet switches must be set for port surveillance to provide a contact output making a contact when a fault appears. Please refer to the manual of the IES-3000 Ethernet switch series to do so.

Connect this contact to a control input of the VX-2000. In the activation setting mode of the VX-2000 setting software, select the function “External Fault CIN” for this control input.

Go to the operation setting mode and select the button [Failure Output]. Select a free line in the failure pattern list (make a new failure pattern) and select the tab “Equipment”. In the list “External Fault CIN”, make a check at the control input used for receiving a fault from the Ethernet switch. Select control output number 7 for this pattern.

New function Enable Failure Buzzer

The new VX-2000 setting software version 3.1.0 provides a setting for the buzzer control of the indication panel. When selected, then control output 8 cannot be used for other functions.

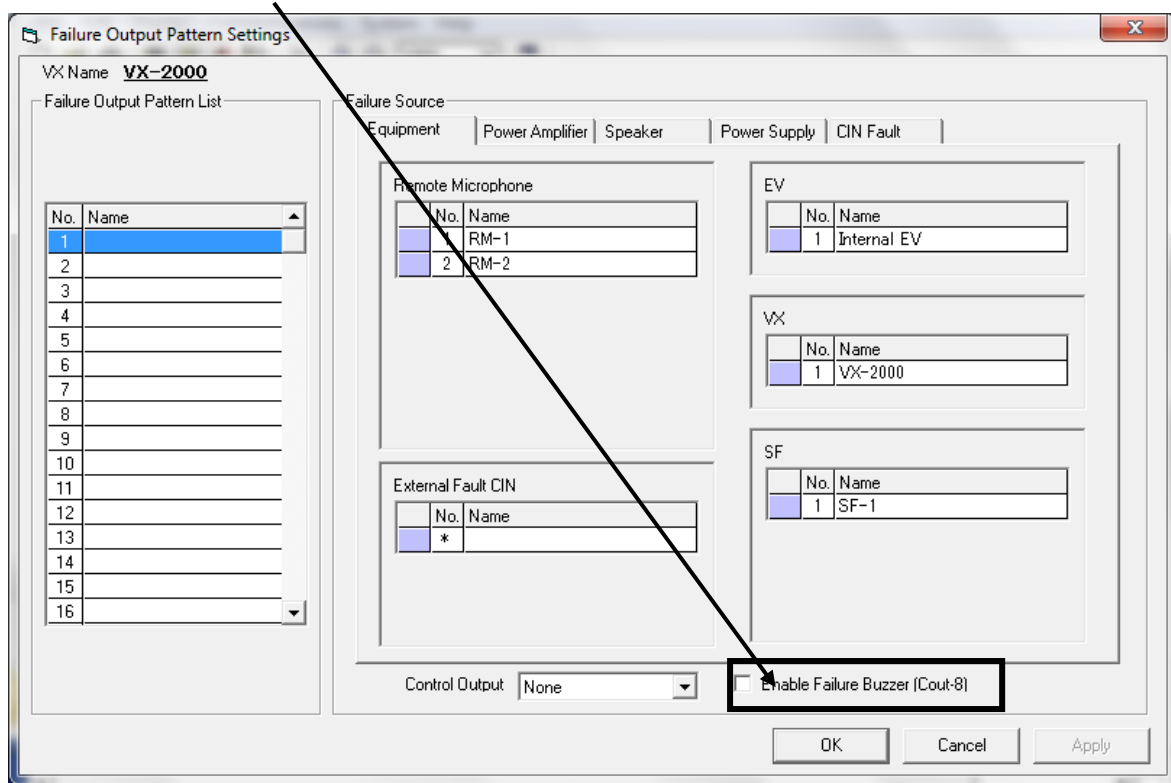

5.2.1.2 Status Indications

No.*	Indication of	connections	Operation setting mode, make a check in
2	Power	DC out of VX-2000DS, VX-3000DS	- (no setting required)
3	Emergency mode	VX-2000 control output 2	[Emergency], tab “Emergency Output”: Cout-2

*: number as on “Appearance Front Panel”, page 3

[]: button of the main menu of the VX-2000 setting software

5.2.2 Control Input Settings for Emergency and Button Controls

The settings are to be made in the activation setting mode. Select the button “Control Input” of the main menu.

Control input	Function setting	Refer to
1, 2	Emergency pattern, Emergency reset, silence	Chapter 4.3
3	Failure output reset	-
6	Failure output receipt (no control output required)	-

5.2.3 Indication of Failures in Fire Alarm Areas (option of EN 54-16)

When using this option, then a failure of each fire area must be indicated. Consider that a fire area may consist of several paging zones, i.e. a fire area can cover a group of zones. The fire areas should be declared by the responsible party (e.g. fire brigade, fire expert) who is aware of the emergency concept.

Failures in of up to 8 fire areas can be indicated. The control outputs 9-16 shall be used for that.

Setting by the VX-2000 Setting Software

- a. In operation mode, select the button [Failure Output].
- b. Select a free line (make a new failure pattern) and
- c. Select the tab “Speaker”.
- d. Make a check into each box (short circuit, break, earth leakage) of each speaker zone that belongs to that fire area.
- e. Select the control output for the corresponding indication LED (refer to next table)
- f. Proceed again from step 2 on for the other fire zones.

Relation of Control Output to indication LED of fire area (FA)

Indication LED	FA 1	FA 2	FA 3	FA 4	FA 5	FA 6	FA 7	FA 8
Control output no.	9	10	11	16	13	14	12	15

6 Connection and Settings for the SX-2000 System

6.1 Connections to SX-2000

Rear right side (mandatory indications)

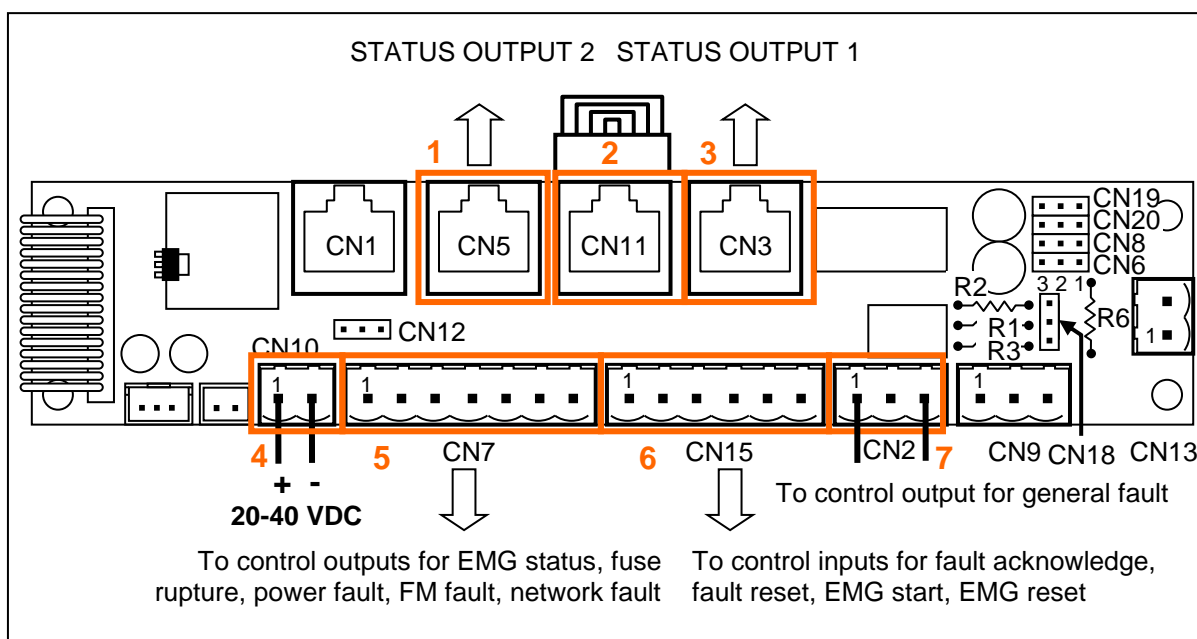

- 1 Connect CN5 to Status output 2 of the SX-2000SM (use Cat5/5E/6 cable)
- 2 Prepare an RJ45 connector with connections between the pins: 1-8, 2-7, 3-6, 4-5 and plug into CN11
- 3 Connect CN3 to Status output 1 of the SX-2000SM (use Cat5/5E/6 cable)
- 4 Connect CN10 with power supply from VX-2000DS or VX-3000DS (don't connect to regulated 24 VDC), + on pin 1, - on pin 2
- 5 Connect to control outputs for EMG status, fuse rupture, power fault, FM fault, network fault. For details refer to table "CN7 main connections"
- 6 Connect to control inputs for fault acknowledge, fault reset, EMG start, EMG reset. For details refer to table "CN15 connections"
- 7 Connect to control output for programmed general fault, pins 1 and 3

CN7 main connections

Pin no.	indication
1	Power LED
2	Emergency mode
3	Fuse rupture
4	COM (ground)
5	Power fault
6	Fireman microphone fault
7	Network fault

CN15 connections

Pin no.	indication
1	Fault acknowledge
2	COM (ground)
3	Fault reset
4	Emergency pattern stop / emergency reset (refer to chapter 3.3)
5	COM (ground)
6	Emergency pattern start

For the connections to the SX-2000 components connections refer to 6.2 Connections at SX-2000 Components on next page.

Rear left side (fire area fault indications or other fault indications)

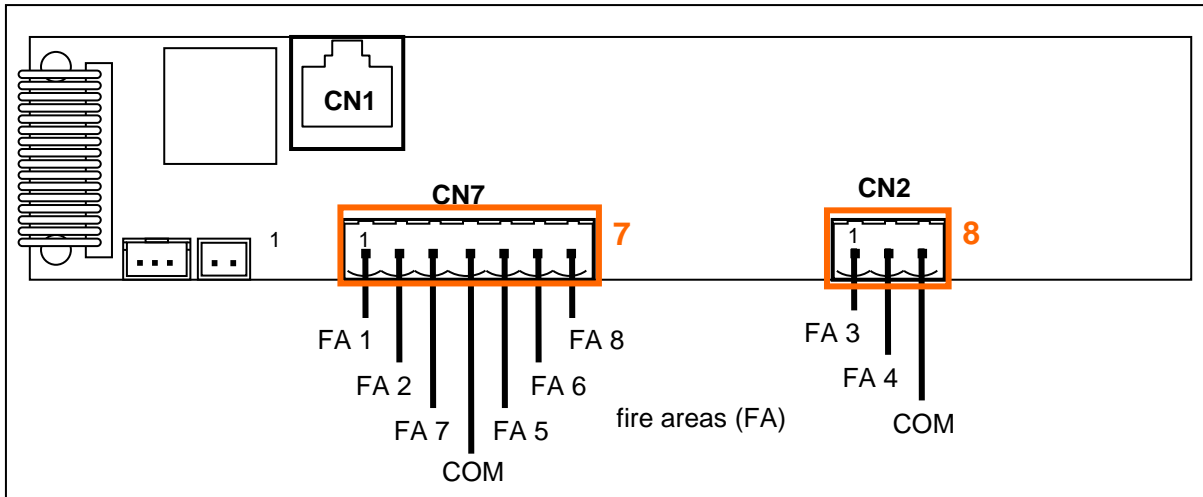

8 Connect to control outputs for faults in the fire areas 1, 2, 5 -8. For details refer to table “CN7 FA connections”

9 Connect to control outputs for faults in the fire areas 3 and 4. For details refer to table “CN2 connections”

CN7 FA connections

Pin no.	indication
1	Fault in fire area 1
2	Fault in fire area 2
3	Fault in fire area 7
4	COM (ground)
5	Fault in fire area 5
6	Fault in fire area 6
7	Fault in fire area 8

CN2 FA connections

Pin no.	indication
1	Fault in fire area 3
2	Fault in fire area 4
3	COM (ground)

For the connections to the SX-2000 components connections refer to 6.2 Connections at SX-2000 Components below.

6.2 Connections at SX-2000 Components

Since the control inputs and outputs of the SX-2000 components are isolated from ground (COM; earth-free), all “C” contacts must be connected together and be connected to the COM of the indication panel.

Example (using control inputs and outputs of the SX-2000SM):

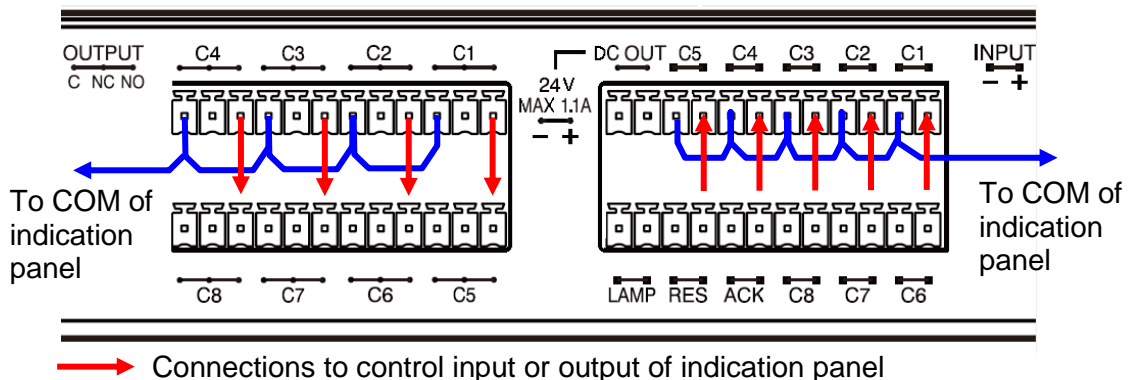

6.3 SX-2000 Settings

6.3.1 Mandatory Indication

Some control outputs are fixed by the SX-2000 system, others require a preparation. Before preparing the failure settings, prepare 5 control output pattern for activating the indication panel IP-EN1-EB. Since any control output can be used for the fault output, here we use the control outputs of the SX-2000SM as an example written in rectangle brackets [#].

6.3.1.1 Fault Indications

In the first step, prepare the “Surveillance Settings”. Set a check for

- “DC Power” of each SX-2000 component
- “DS Link” of each DS link connected to VX-2000DS / VX-3000DS
- “RM” on the SX-2100 where an emergency/fireman microphone is connected
- Each amplifier (used for emergency)
- Each loudspeaker line (used for emergency)

In the second step proceed as described below:

No.*	Indication of	SX-2000 connector to IP-EN1-EB connector	Pattern Settings / Failure Output
4	General fault	Status control output 1 to CN3 and any control output [6] to CN2, pins 1 and 3	- select DS LINK, DC FUSE, RM LINK; all SX-2000 components, all emergency/fireman microphones, all amplifiers and all speaker lines - select the “Failure status output” for the general fault indication of the indication panel [6]
5	CPU fault		
6	Power fault	Any control output [1] to CN7 pin 5	- select DS LINK; - select the “Failure status output” for controlling the power fault indication of the indication panel [1]
7	Fireman/emergency microphone fault	Any control output [2] to CN7 pin 6	- select “RM LINK”; - select each fireman/emergency microphone of the SX-2100AI - select the “Failure status output” for the fireman microphone fault indication of the indication panel [2]
8	Fuse fault	Any control output [3] to CN7 pin 3	- select “DC FUSE” - select the “Failure status output” for the amplifier fault indication of the indication panel [3]
9	Network fault	Any control output [4] to CN7 pin 7	Event Settings: assign “external failure input” to all control inputs to which the fault control outputs of the Ethernet switches are connected to. Pattern settings / failure Output: make a pattern for each Ethernet switch fault: - select the “external failure input” prepared (above) - select the “Failure status output” for controlling the <u>network fault indication</u> of the indication panel [4] Make another pattern for each Ethernet switch fault: - select the “external failure input” prepared (above) - select the “Failure Status Output” for the <u>general fault indication</u> of the indication panel [6]
12	buzzer	Status control output 2 to CN5	No settings required (fixed function)

*: number as on “Appearance Front Panel”, page 3

6.3.1.2 Status Indications

No.*	Indication of	SX-2000 connector to IP-EN1 connector	Settings
2	Power	-	- (no setting required)
3	Emergency mode	Any control output [5] to CN7 pin 2	Event Setting / System event: in “Control output pattern of emergency status“, assign the control output [5] for controlling the indicating of the emergency status

*: number as on “Appearance Front Panel”, page 3

6.3.2 Indication of Failures in Fire Alarm Areas (option of EN 54-16)

When using this option, then a failure of each fire area must be indicated. Consider that a fire area may consist of several paging zones, i.e. a fire area can cover a group of zones. The fire areas should be declared by the responsible party (e.g. fire brigade, fire expert) who is aware of the emergency concept.

Failures in of up to 8 fire areas can be indicated. Any control output can be used for that.

Setting by the SX-2000 Setting Software

1. In the surveillance settings, make a check for each speaker zone that shall be monitored.
2. In the pattern settings, control outputs, prepare as many control output pattern as required for the failure indications of the fire zones.
3. In the pattern settings, failure output, make a failure pattern for each fire area. To do so, activate the zones in each fire area by a mouse click and select the control output pattern used for the control of the particular fire zone of the field failure status output

Relation of Control Input connection of the fire area’s Indication LED

The connectors CN2 and CN7 of the right board (view from rear) contain the control inputs for the failure indications in the fire areas.

Indication LED	FA 1	FA 2	FA 3	FA 4	FA 5	FA 6	FA 7	FA 8	COM	COM
Connector no.	CN7	CN7	CN2	CN2	CN7	CN7	CN7	CN7	CN2	CN7
Pin no.	1	2	1	2	5	6	3	7	3	4

7 Specifications

Supply voltage	20 – 40 VDC
Current consumption	60 mA max.
Emergency control input	Contact or 12 VDC / 24 VDC (selectable)
Contact control	Open voltage: 24 VDC, current: 12 mA
Voltage control	12 VDC, 12 mA (1 kohm) or 24 VDC, 12 mA (2 kohm); isolated
General fault control output	NC, NO; max. 40 VDC, 100 mA; isolated
Dimensions (W x H x D)	483 x 44 x 47 mm (without plugs) (19", 1U)
Weight	470 g (incl. plugs)
Finish	Aluminium, brushed, black

8 Accessories

2-pin removable screw terminal	2
3-pin removable screw terminal	3
6-pin removable screw terminal	1
7-pin removable screw terminal	2
Keys	2

9 Optional Accessories

Labels in other languages request

24.06.2016

Traceability Information for EU (EMC directive 2004/108/EC); manufacturer:



TOA Electronics Europe GmbH

Süderstraße 282 ♦ 20537 Hamburg ♦ Germany

Tel.: +49-(0)40-25 17 19-0 ♦ Fax: +49-(0)40-25 17 19-98 ♦ URL: www.toa.eu